

Generator Condition Monitor

AIR COOLED APPARATUS

Corrective action prompted by early warning of generator overheating can mean the difference between a brief shutdown for minor repairs and a major overhaul involving weeks, or even months, of costly downtime.

SPECIFICATIONS

MEASUREMENT CHARACTERISTICS

Technology Principle	Submicron particle detector
Air Flow Rate	Adjusted by Zone Manifold, nominal 14 LPM
Readout (LED bar graph)	
Ambient Air	0 to 100% scale
Generator Air	0 to 100% scale

ELECTRICAL CHARACTERISTICS

Input Voltage	115 VAC, 50/60 Hz (230 VAC, 50/60 Hz optional)
Output Relays	
Ambient Alarm, Zone 1	3 A @ 120/240 VAC
Generator Alarm, Zone 2	3 A @ 30 VDC
Differential Alarm	100 mA @ 125 VDC
Warning	
System Trouble	
Flow Trouble	
4-20 mA outputs	500 ohms max
Ambient Air	4-20 mA = 0-100%
Generator Air	4-20 mA = 0-100%
Differential	4-20 mA = 0-100%
Area Classification	General Purpose

MECHANICAL CHARACTERISTICS

Overall Dimensions	24" h x 24" w x 11.75" d (610 mm x 610 mm x 299 mm)
Weight, approximate	85 lbs (38.6 kg)
Connectors, gas inlet	3/8" NPT, standard
Ambient temperature	32-122 F (0-50 C)
Relative Humidity	0-95%
Controls	5-key switch keypad with LED indicators and liquid crystal display



Advancements in air-cooled generator designs have resulted in increasingly higher power ratings. The higher power densities place significantly greater stresses on materials and structures, making slight decreases in cooling efficiencies much more critical. Probability of overheating in these air-cooled machines becomes greater as designs are pushed closer to their critical limits.

The GCM-A₂ warns of an impending failure much faster than RTD's or thermocouples. Why? Because RTD's and thermocouples need to be physically near the hotspot, or wait until overheating progresses to the point that the temperature near the RTD or thermocouple rises sufficiently for the sensor to detect it. This results in a significantly larger "fault," possibly a catastrophic one. The GCM-A₂, on the other hand, detects the pyrolysis particles emitted into the cooling air as a result of overheating or arcing virtually anywhere in the machine.

HOW THE GCM-A₂ WORKS.

The GCM-A₂ monitors two air sample lines using a submicrometer particle detector. One line monitors ambient air, which serves as a reference. The other line is used to monitor generator cooling air, which is then compared against the particle level of the reference. High particle levels in the generator cooling air, without a corresponding increase in the ambient air, confirms the source of the pyrolysis particles is from within the generator.

In the event overheating occurs, large numbers of pyrolysis products are created in the generator cooling air. When the signal level corresponding to the difference between the generator cooling air and ambient air exceeds a predetermined (adjustable) set point, the result is a differential alarm, causing the alarm contacts to close. Individual contacts will also close if the outputs corresponding to the ambient air and/or generator cooling air exceed predetermined (adjustable) set points.

FEATURES AND BENEFITS

- Continuous real time monitoring of overheating and arcing
- Continuous self-checking diagnostics, microprocessor-controlled
- LCD Display – status indicator during normal operating mode; provides diagnostic and programming prompts when needed
- Bar Graphs – one provides continuous, real-time indication of ambient signal, while the second one provides real-time indication of generator signal
- Alarm points and system sensitivity are adjustable
- Flexible system design tailored to individual situations

OUTLINE

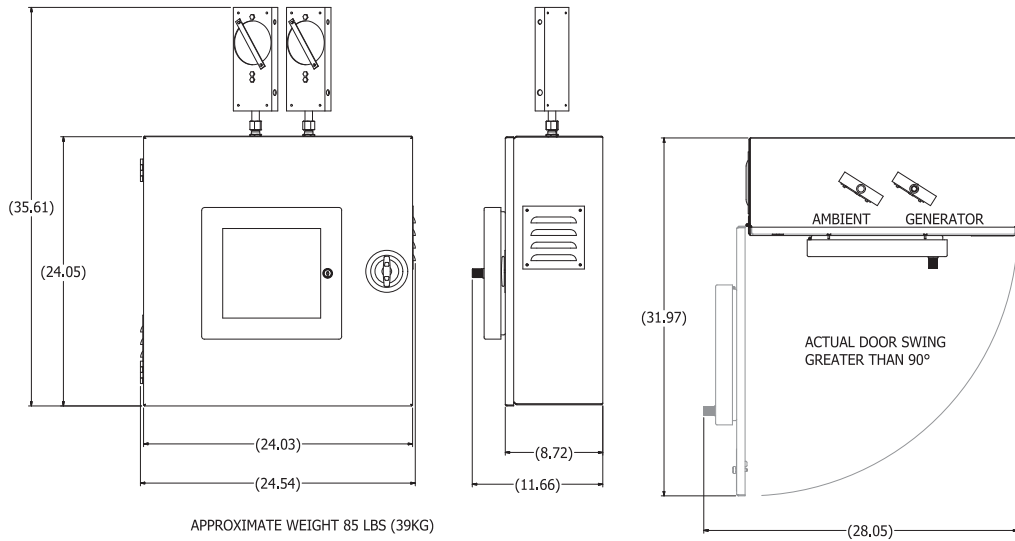

APPROXIMATE WEIGHT 85 LBS (39KG)

P & ID

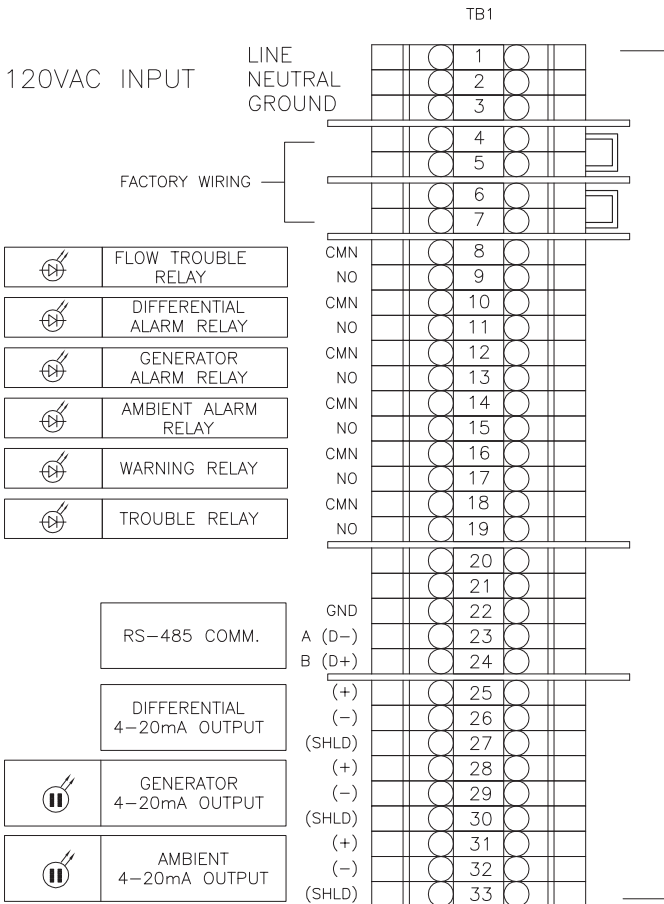
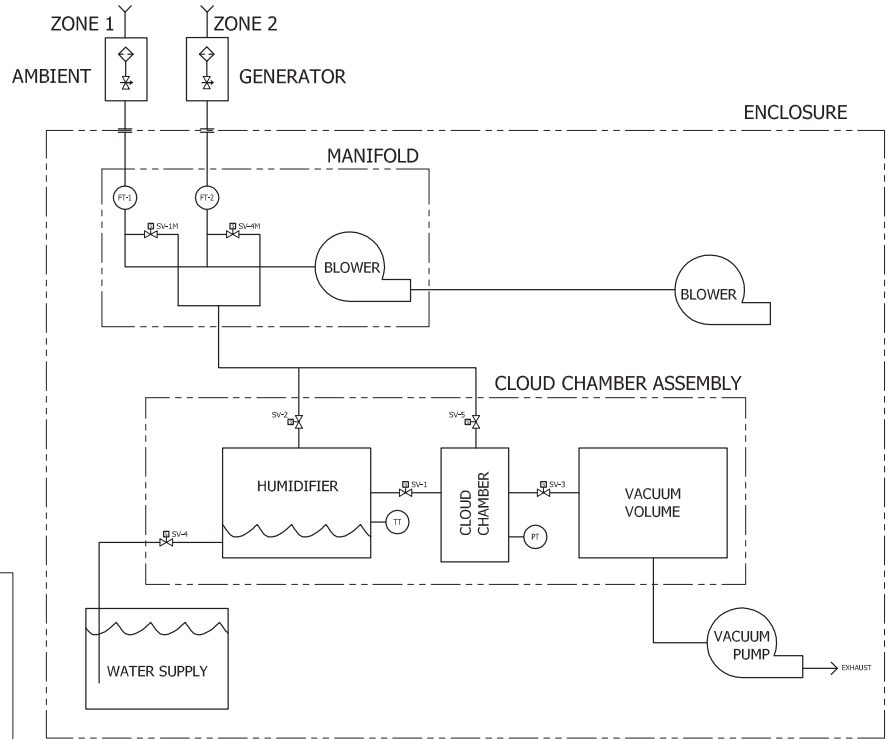

CUSTOMER CONNECTIONS



Environment One Corporation
 Utility Systems / 2773 Balltown Road / Niskayuna, NY 12309 USA
 Voice: 518.346.6161 / Fax: 518.346.4382 / www.eone.com/solutions

A PCC Company / LM000408